



## **New Construction Inside-Wiring Requirements from TDS**

Building a home is an investment. TDS is also making an investment in your new community. We are building a Fiber to the Home network in select communities across our national serving area. What does this mean for homeowners? It means they'll have access to ultra high-speed Internet and more. Now, they can work at home, participate Internet gaming or online auctions faster than cable modems and utilize complex entertainment video configurations. In the future, Fiber technology allows you to have a "smart home" with home security capabilities, smart appliances and much more.

**Homeowners:** Taking a few extra steps now to place the proper wiring inside the walls of your new home will save you costly installations in the future and give you the ability to adapt quickly to new technologies. Future-ready your home by following TDS Telecom's inside wire recommendations during your construction. Talk with your builder and electrician; tell them you want a technology-ready home. Yes, it will cost a little more, but the long term benefits certainly outweigh a modest expense today.

**Builders:** Ask your clients what's important to them. Homes of today need to be ready to handle the technology consumer's demand tomorrow. And your customers are not going to want to rewire and drill holes in their new walls after they are enjoying their beautiful new home. So talk with them now, you'll have a highly satisfied customer, higher resell values and a reputation as a smart builder.

### **How will TDS address homes in our Fiber Subdivisions?**

TDS will address the home in essentially the same way as before. We need to replace the type of interface box we use on the side of the home. Since complex electronics are needed to break apart the Fiber signal back into voice, high speed Internet and Video, this box also needs power and an Uninterruptible Power Source (UPS). Both of these devices are provided for, owned by and maintained by TDS Telecom. We will now have the ability to monitor all the way to the box on the side of the home, often knowing about problems before the

customer.

[picture of ONT and UPS and how we would like the wiring to look –on the outside of the home]

### **Wiring Recommendations for Electricians and Home Builders.**

Although we will be using a different termination box on the outside of the home, TDS Telecom will be terminating and presenting our services as usual. Below are a set of recommendations:

#### ***Demarcation Point –Inside the Home***

TDS will place our demarcation point near the power service entrance. Inside the home on the other side the wall from the demarcation point, we need:

- GFI Electrical Outlet – power for the UPS
- Alternatively, hardwire UPS –based on local codes
- An additional piece of plywood for mounting
- Conduit through wall –minimum 1 1/8” I.D. recommended
- Conduit from attic to basement –required for any future wiring needs.

#### ***Central Distribution Point***

Ideally, the Central Distribution Point is located on the other side of the wall from the Demarcation Point. It can be some other place inside the home, but that is a second choice. The Central Distribution Point should look like the following: We are suggesting using something similar to the Leviton Integrated Network Structured Media Center (pictured below) available at most Home Depot® stores or [www.twacom.com](http://www.twacom.com).

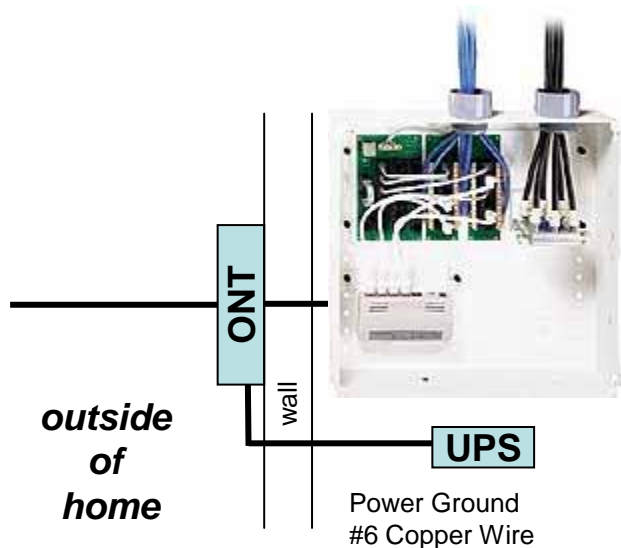

### ***In each room***

**Recommended Configuration**—the recommended solution is to run **2 CAT5e and 2 RG6 to each room in the home**. This configuration will give the customer the greatest flexibility for future services. See *wiring / service matrix below*.

**Alternative Configuration** —for an alternative wiring solution for fewer rooms take **2 CAT5e and 2 RG6's to homeowner specified "media rooms"**, likely the great room or family den. These rooms will serve as the hubs for home entertainment, holding the main digital set top boxes, networked personal video recorders (TIVO®) and other devices. Other rooms in the home can be wired with 1 CAT5e and 1 RG6. See *wiring / service matrix on next page*.

**Not Recommended Configuration** -we do not suggest running just **one CAT5e and RG6 to each room**. This configuration will limit what the homeowner can select for entertainment and communication devices as well as create costly home wiring jobs in the future.

### **Consumer Demand for Technology is Increasing**

The most important reason TDS is building fiber networks in our communities is consumer demand. Today's consumers want choices and are high consumptive users of entertainment. From the Computer to the TV, today's consumers are tech savvy. A simple phone line request of the past, now has with it demands of high speed internet, fax lines and multiple calling services. Homes need to be future ready. A solid wiring infrastructure today is a simple step to take to make sure homes are ready for what technology brings.

**Whole house High Speed Internet** —Customers are requesting high speed internet in multiple rooms, kitchens, bedrooms, living rooms and home offices every room needs to be ready. Wireless has made great strides in this area, but networking over CAT5e still is the most reliable and secure method available.

**Whole house video** — Consumers are networking televisions and sharing content. Some dual tuner DISH and DIRECT TV receivers are requiring multiple RG6 runs for picture in picture, the ability to watch one show and record another or to decode the satellite signal for more than 1 TV (requiring fewer set top boxes). The average customer has 2.5 TV's per household connected to Cable TV or Satellite service.

**Home Networking for a Home Office** —Home offices are in high demand, but being away from the office means you need even more connections. Sharing printers, files and Internet access and needing to maintain connections for the phone and fax lines at the same time requires multiple CAT5e connections into the home office area. Plus, with the suggested wiring configuration,

moving a home office is as easy as unplugging from one room and moving to the next. Or you can network the room specifically for this function and wire it as needed.

**Family and Home Monitoring** –Family security is a new and growing need for many families. Keeping an eye in side your home to view from work or other locations using the Internet or from a TV in the den requires a wiring infrastructure to support it.

**Wiring / Service matrix**

The below matrix outlines the wiring requirements for individual and combination packages. The recommended solution will support any of these combinations.

	RG6 1	RG6 2	CAT5 1	CAT5 2
<b>Phone Service</b>				
1 phone line				
2 phone lines				
<b>High Speed Internet</b>				
Cable Modem				
Home Networking				
DSL				
<b>Video Service</b>				
Standard Cable TV				
Digital Cable TV				
1 Tuner DBS (CAT5 for PPV)				
2 Tuner DBS				
2 Tuner DBS with Network PVR				
<b>Likely Combinations</b>				
Phone and Cable TV				
Phone and Cable Modem				
Phone and DSL				
Phone and 1 Tuner DBS and DSL				
Phone and 2 Tuner DBS and DSL				
Phone, 2 Tuner DBS with Network PVR				
Phone, Digital Cable with Network PVR, DSL				

## Recommended Solution –in detail

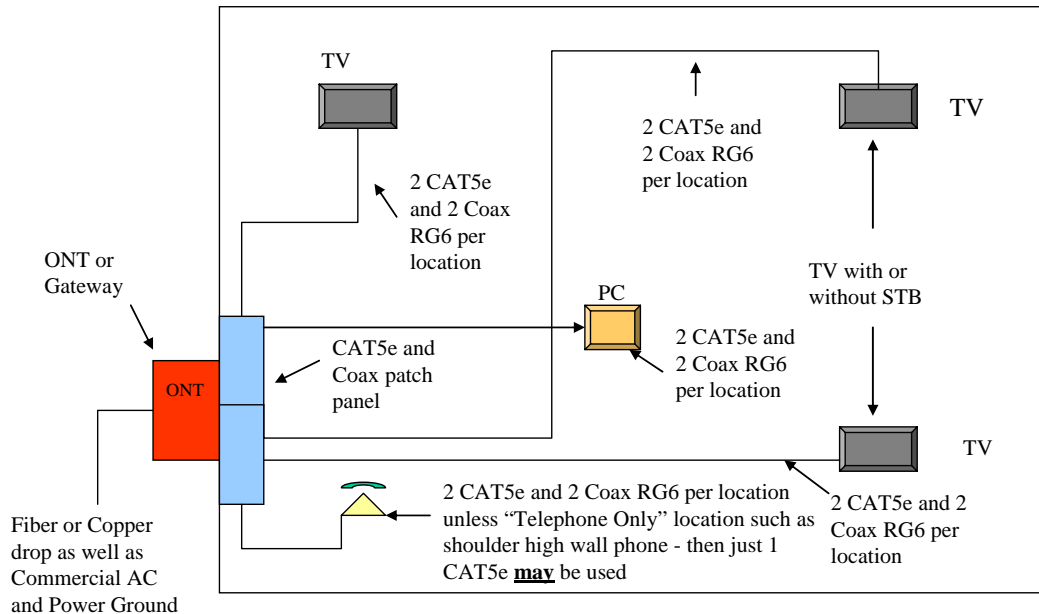

### HSD (High Speed Data) and SDV (Switched Dig. Video) wiring

- Use CAT5e wiring
- Transports 100 Mbs up to 300'
- Average STB (Set Top Box) will require no more than 18 to 20 Mbs/location (passing current HDTV compression)
- Compression is only going to improve (Mpeg2 to Mpeg 4/WM9)
- CAT5e is sufficient for future applications for the foreseeable future.

### Coax Wiring

- Use standard RG6 capable of passing 3Gig tests
- This will allow the passing of HDTV
- Recommended that 2 RG-6 cables be run to each location in case pass thru from one STB is needed to feed another TV in a non STB location
- Radius of wire bends needs to be approximately 45 deg so as to not cause RF traps

### Basic Telephone Wiring

- New multiplex cable now uses 2 CAT5e and 2 RG-6 wires under the same sheath and so a separate CAT3 would not be needed. Could use if preferred.